

# **H&S PARTS BOOK**

## **S2180 SPREADER**

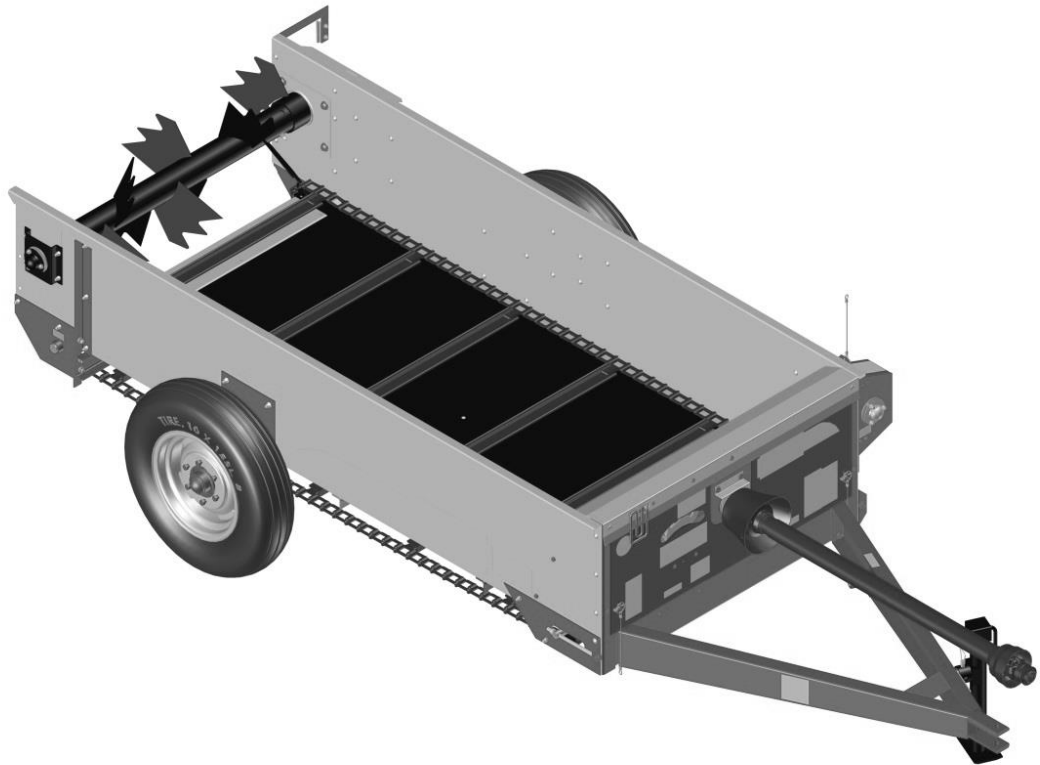

Revision #01  
Starting Ser. #610950

Part #71216  
HSMFG0116

**P.O. BOX 768, MARSHFIELD, WI 54449**  
**(715) 387-3414 FAX (715) 384-5463**  
**[www.hsmfgco.com](http://www.hsmfgco.com)**

# CONTENTS

Instruction For Ordering Parts - About Improvements.....	1
Figure 1 - Front Pole Assembly.....	2-3
Figure 2 - Input Shaft Assembly.....	4-5
Figure 3 - Shifting Components.....	6-7
Figure 4 - Panels & Manual Holder.....	8-9
Figure 5 - Side Panels.....	10-11
Figure 6 – Front Idler Shaft Assembly.....	12-13
Figure 7 - Floor Assembly.....	14-15
Figure 8 - Rear Idler Shaft Assembly.....	16-17
Figure 9 - Side Shaft Assembly.....	18-19
Figure 10 - Side Shaft Panel & Guards.....	20-21
Figure 11 - Hub & Spindle Assembly.....	22-23
Figure 12 - Beater Assembly.....	24-25
Figure 13 – Gearbox.....	26-29
Figure 14 – Pto.....	30-31
Figure 15 - Optional Pan.....	32-33
Parts Notes.....	34

## **INSTRUCTIONS FOR ORDERING PARTS**

All service parts should be ordered through your authorized H&S dealer. They will be able to give you faster service if you will provide them with the following

1. Model & Serial number is located on the left, rear main frame of your unit.
2. All reference to left or right apply to the machine as viewed from the rear.
3. Parts should not be ordered from illustration only. Please order by complete part number.
4. If your dealer has to order parts - give shipping instructions:

VIA truck - large pieces (please specify local truck lines)

VIA United Parcel Service (include full address)

<b>H&amp;S MFG. CO. INC.</b>	
<b>MARSHFIELD, WIS.</b>	
MOD. NO.	<input type="text"/>
SER. NO.	<input type="text"/>
DESCR.	<input type="text"/>

PLEASE RECORD NUMBERS FOR YOUR UNIT FOR QUICK REFERENCE

### **ABOUT IMPROVEMENTS**

**H&S IS CONTINUALLY STRIVING TO IMPROVE IT'S PRODUCTS**

We must therefore, reserve the right to make improvements or changes whenever it becomes practical to do so without incurring any obligation to make changes or additions to the equipment previously sold.

# FIGURE 1 FRONT POLE ASSEMBLY

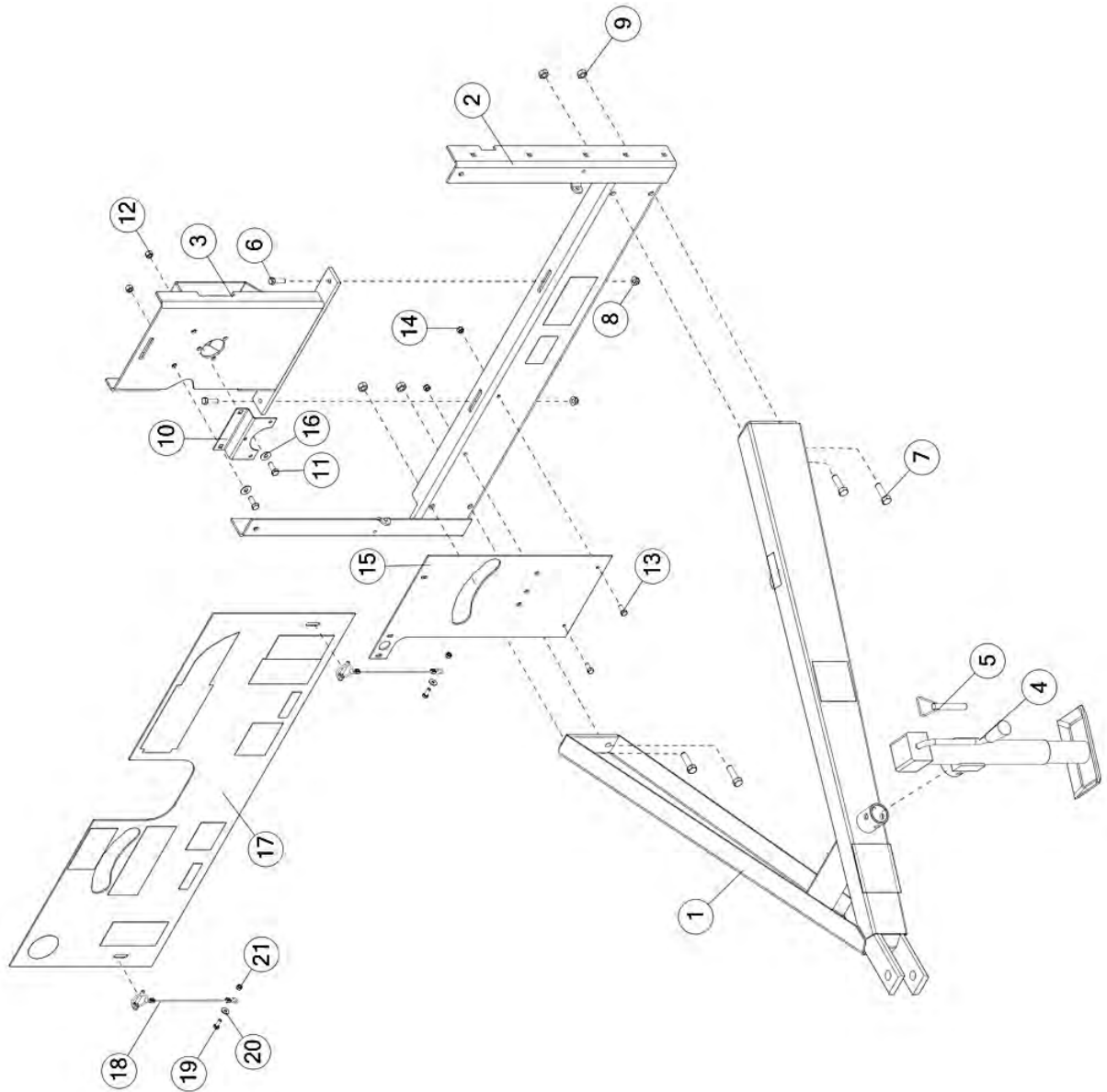

# FIGURE 1

## FRONT POLE ASSEMBLY

<u>ITEM</u>	<u>QTY</u>	<u>PART #</u>	<u>DESCRIPTION</u>
1	1	70996	ASSM, FRONT POLE WITH DECALS
2	1	72076	FRAME ASSY WITH DECALS, FRONT
3	1	68993	WLDMT, FRAME, FRONT POST
4	1	12N116	JACK, 2000# SIDE WIND
5	1	12N117	PIN, 0.56, 5.19, JACK
6	2	YBHH12035	BOLT, 3/8"-16 X 1-1/4" GR. 5
7	4	YBHH16055	BOLT, 1/2 X 1-3/4 GR 5
8	2	YNFG12006	HEX NUT, FLANGE, NYLOCK, 3/8-16, GR F, ZINC
9	4	YNL16005	HEX NUT, TOP LOCK, 1/2-13
10	1	80N13	CENTER BEARING BRACKET
11	2	YBHH12010	BOLT, 3/8 X 1 GR 5
12	2	YNL12005	HEX NUT, TOP LOCK, 3/8-16
13	2	YBHH10105	BOLT, 5/16 X 3/4 GR 5
14	2	YNNY10005	HEX NUT, NYLON LOCKNUT, 5/16-18
15	1	72001	BRKT, SHIFTING MECHANISM
16	2	YWFL12005	WASHER, FLAT, 3/8 USS
17	1	72048	ASSM, PANEL, POLY, FRONT, WITH DECALS
18	2	S122	LANYARD, CLIP PIN CABLE
19	2	YBHH08100	BOLT, 1/4 X 3/4 GR 5
20	2	YWFL08005	WASHER, FLAT, 1/4 USS
21	2	YNNY08005	HEX NUT, NYLON LOCKNUT, 1/4-20

# **FIGURE 2** **INPUT SHAFT ASSEMBLY**

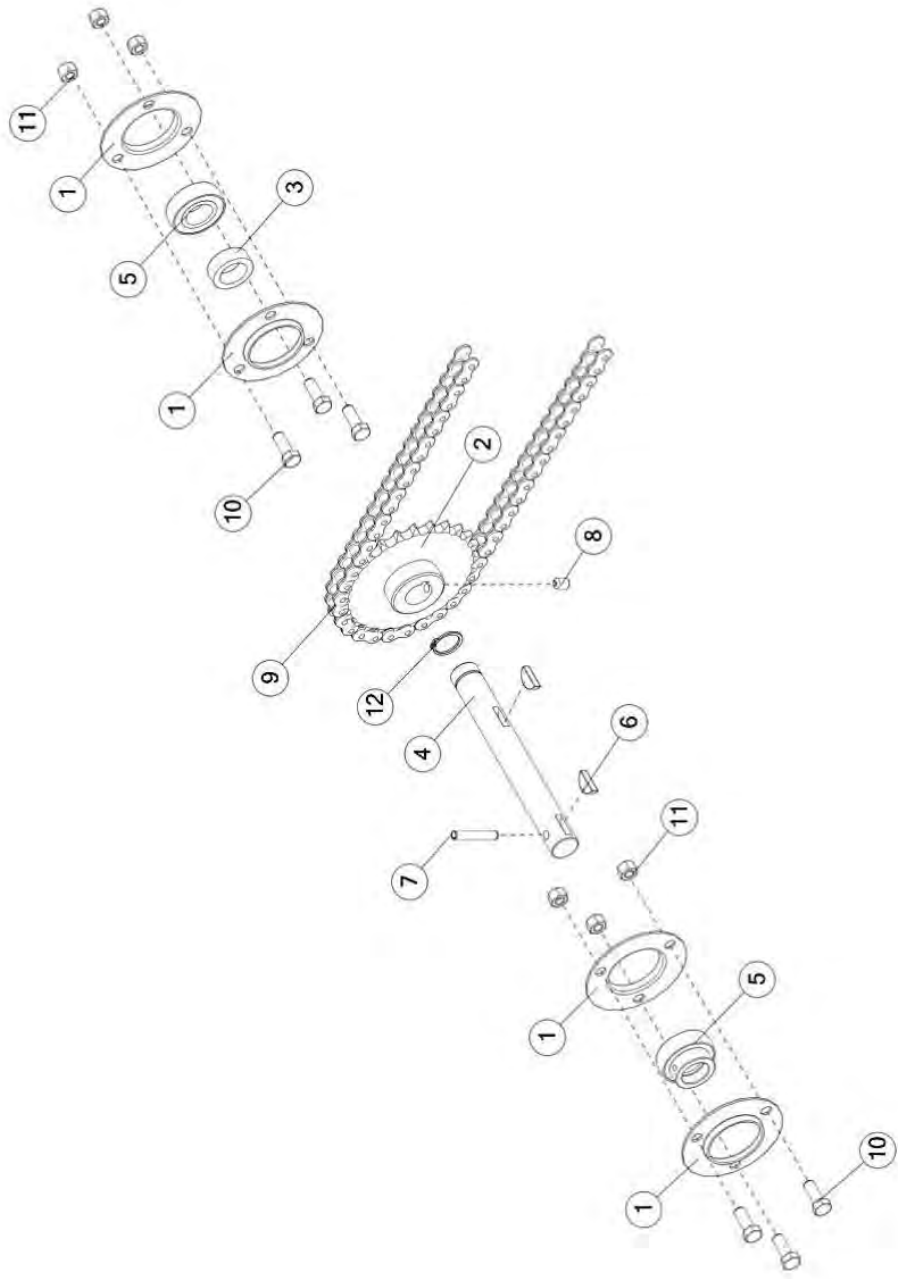

## FIGURE 2

### INPUT SHAFT ASSEMBLY

<u>ITEM</u>	<u>QTY</u>	<u>PART #</u>	<u>DESCRIPTION</u>
1	4	4C7	FLANGE, BEARING, Ø3.75 OD, Ø1.98 ID
2	1	69783	SPKT, 50, B, 25, 1.00 SHAFT
3	1	70727	TUBE, RND, STR, 1.5 X 0.24 X 0.51
4	1	80N7	INPUT SHAFT
5	2	4C8	BEARING W/COLLAR, 1.00"
6	2	5B10	KEY, WOODRUFF, 1/4" X 1.00"
7	1	YPEX10015	EXPANSION PIN, 5/16" X 1-3/4"
8	1	YSSO12005	SET SCREW, SOCKET, 3/8-16 X 1/2
9	1	70200	CHAIN, ROLL, 50 X 119
10	6	YBHH12010	BOLT, 3/8 X 1 GR 5
11	6	YNTL12005	HEX NUT, TOP LOCK, 3/8-16
12	1	3G21	HEAVY DUTY EXTERNAL SNAP RING

**FIGURE 3**  
**SHIFTING COMPONENTS**

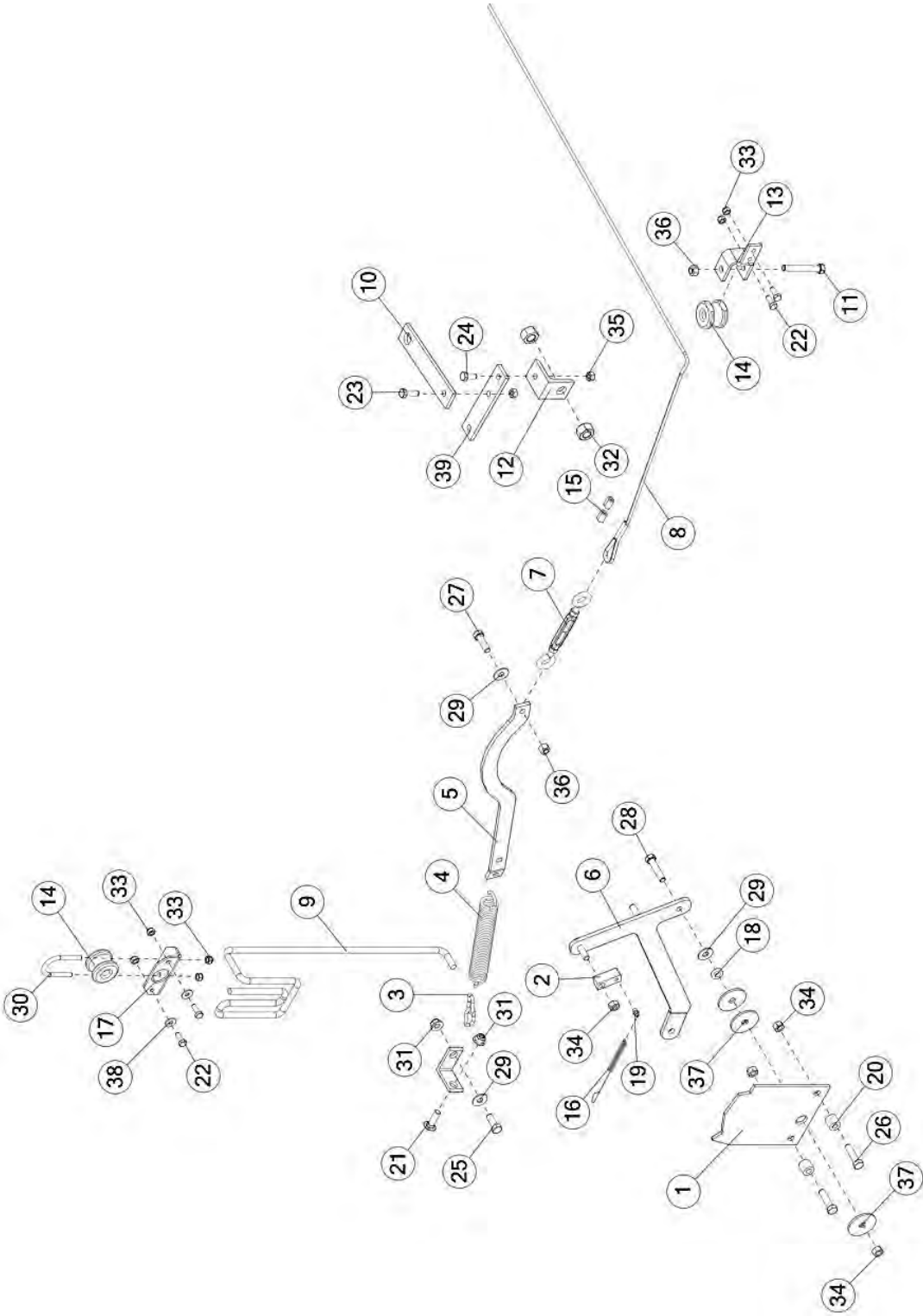



## **FIGURE 3**

### **SHIFTING COMPONENTS**

<b><u>ITEM</u></b>	<b><u>QTY</u></b>	<b><u>PART #</u></b>	<b><u>DESCRIPTION</u></b>
1	1	23N283	STOP BRACKET
2	1	23N282	BRKT, 5/8, SHIFTERDOG
3	1	70535	ASSM, CHAIN, 2 LINKS
4	1	10R14	SPRG, COIL, 8.5, 25, TENS
5	1	71284	BRKT, PIVOT LINK
6	1	72015	WLDMT, LEVER, SHIFTER
7	1	F84	ASSM, TURNBUCKLE
8	1	70713	CABLE, 0.19 X 121, SHIFTER
9	1	23N183	ROPE, 0.38 X 43.03
10	1	23N289	SHIFTER ROD LEVER FULCRUM
11	1	YBHH12095	BOLT, 3/8-16 X 2-1/2 GR 5 FULL THREAD
12	1	23N291	BRKT, ROD, SHIFTER
13	1	71566	BRKT, CABLE GUIDE
14	2	F33	SIDE CABLE GUIDE
15	4	71279	SLEEVE, 0.13 X 0.63
16	1	23N284	SPRG, EXT, COIL, 5.50 X 6.95, 1.20, SHIFTER DOG
17	1	71972	CABLE GUIDE BRKT, FRONT
18	1	23N297	TUBE, RND, STR, 0.75 X 0.19 X 0.21, DOM
19	1	G89	ZERK, 1/4"-28 STRAIGHT
20	2	ST81	EXTENSION SPACER, 11/16"
21	1	YBCR12020	CARR. BOLT, 3/8 X 1-1/4 GR 5
22	4	YBHH08100	BOLT, 1/4 X 3/4 GR 5
23	1	YBHH10010	BOLT, 5/16-18 X 1 GR 5
24	1	YBHH10105	BOLT, 5/16 X 3/4 GR 5
25	1	YBHH12010	BOLT, 3/8 X 1 GR 5
26	2	YBHH12025	BOLT, 3/8-16 X 1-1/2 GR 5
27	1	YBHH12035	BOLT, 3/8"-16 X 1-1/4" GR. 5
28	1	YBHH12060	BOLT, 3/8 X 1-3/4 GR 5
29	3	YWFL12005	WASHER, FLAT, 3/8 USS
30	1	YBPU08005	PIPE U BOLT, 1/4 X 3/4
31	2	YNFG12006	HEX NUT, FLANGE, NYLOCK, 3/8-16, GR F, ZINC
32	2	YNHX20005	HEX NUT, 5/8-11 PLATED
33	6	YNNY08005	HEX NUT, NYLON LOCKNUT, 1/4-20
34	4	YNRL12005	HEX NUT, REVERSIBLE-SIDE LOCK, 3/8"-16
35	2	YNTL10005	HEX NUT, TOP LOCK, 5/16-18
36	2	YNTL12005	HEX NUT, TOP LOCK, 3/8-16
37	3	YWCU12005	WASHER, CUSTOM, FLAT
38	2	YWFL08005	WASHER, FLAT, 1/4 USS
39	1	23N290	BRKT, SHIFTER ROD

**FIGURE 4**  
**PANELS & MANUAL HOLDER**

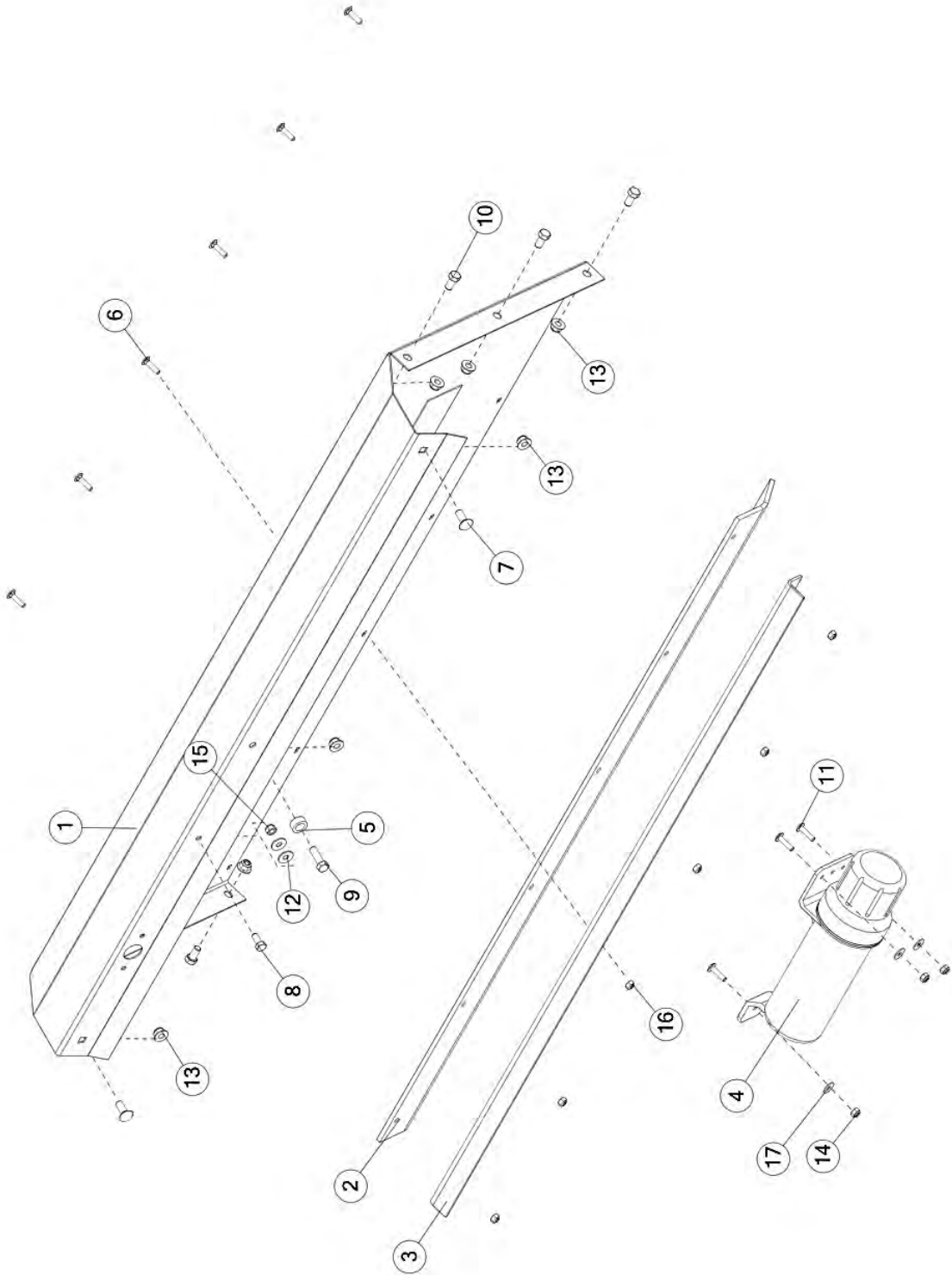

## FIGURE 4

### PANELS & MANUAL HOLDER

<u>ITEM</u>	<u>QTY</u>	<u>PART #</u>	<u>DESCRIPTION</u>
1	1	72000	ASSM, PANEL, FRONT, WITH DECALS
2	1	12N69	FRONT RUBBER
3	1	80N66	FRONT RUBBER STRAP
4	1	S522	MANUAL HOLDER
5	1	80N11	FRONT POST SPACER
6	6	YBCR08005	CARR. BOLT, 1/4-20 X 1 GR. 5 (ZINC)
7	2	YBCR12010	CARR. BOLT, 3/8 X 1 GR. 5
8	1	YBHH10105	BOLT, 5/16 X 3/4 GR 5
9	1	YBHH12035	BOLT, 3/8"-16 X 1-1/4" GR. 5
10	6	YBHH12135	BOLT, 3/8 X 3/4 GR 5
11	3	YSTM08005	TRUSS HEAD MACH, SCREW, 1/4-20 X 1 GR.5 ZINC
12	2	YWFL10005	WASHER, FLAT, 5/16 USS
13	9	YNFG12006	HEX NUT, FLANGE, NYLOCK, 3/8-16, GR F, ZINC
14	3	YNNY08005	HEX NUT, NYLON LOCKNUT, 1/4-20
15	1	YNNY10005	HEX NUT, NYLON LOCKNUT, 5/16-18
16	6	YNTL08005	HEX NUT, TOP LOCK, 1/4-20
17	3	YWFL08005	WASHER, FLAT, 1/4 USS

**FIGURE 5**  
**SIDE PANELS**

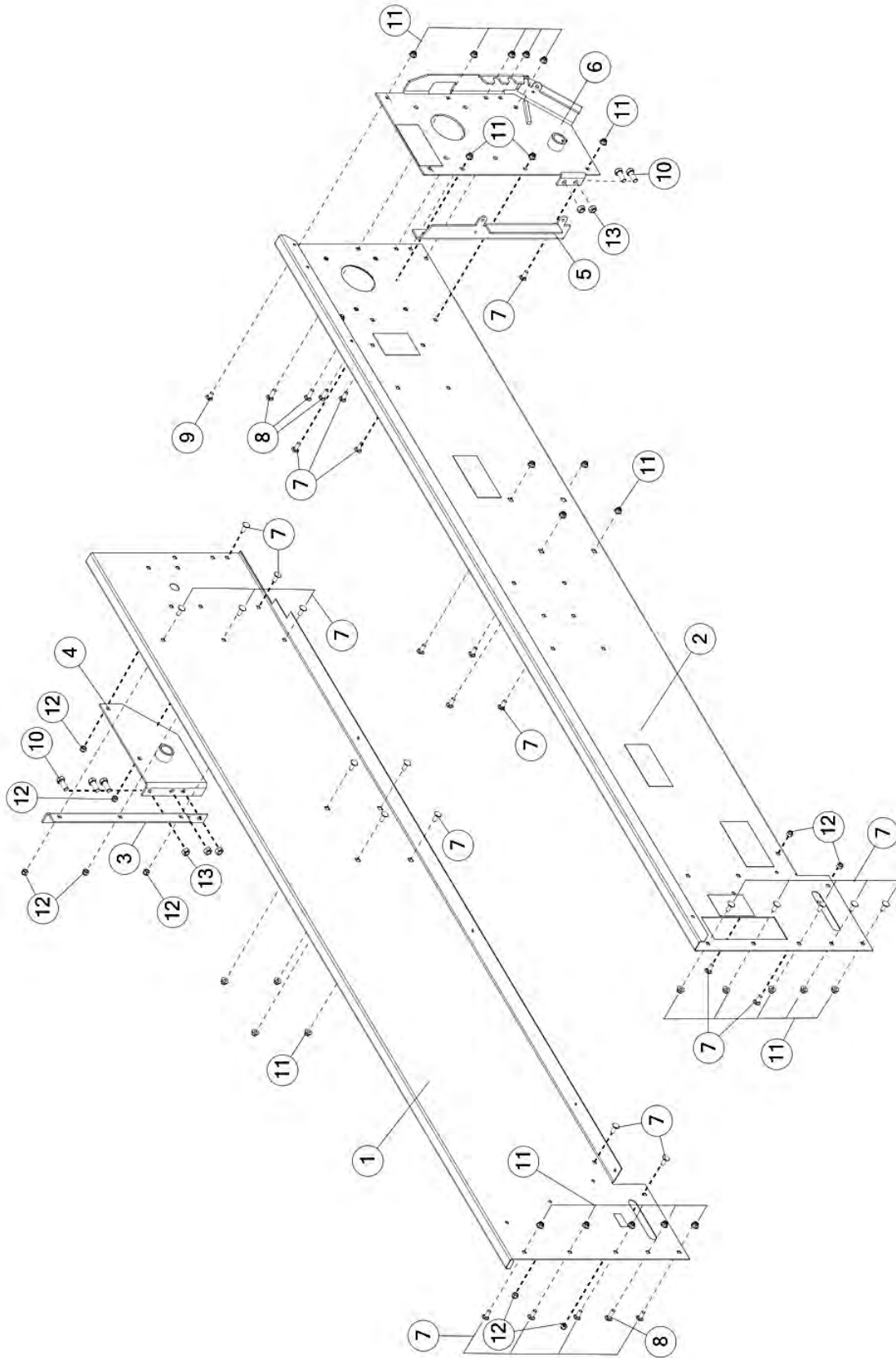

## **FIGURE 5** **SIDE PANELS**

<b><u>ITEM</u></b>	<b><u>QTY</u></b>	<b><u>PART #</u></b>	<b><u>DESCRIPTION</u></b>
1	1	71159	ASSM, RH PANEL WITH DECALS
2	1	72091	ASSM, LH PANEL WITH DECALS
3	1	67469	PLT, 22.0 X 2.94 X 0.19, RH SIDE BRACE
4	1	71171	ASSM, FRAME, REAR, RH, WITH DECAL
5	1	72079	FORMED PLATE, 19.67 X 5.28 X .19
6	1	72080	FRAME ASSY, LH, REAR, WITH DECALS
7	28	YBCR12010	CARR. BOLT, 3/8 X 1 GR. 5
8	4	YBCR12020	CARR. BOLT, 3/8 X 1-1/4 GR 5
9	1	YBCR12065	CARR. BOLT, 3/8 X 1-1/4 GR 5
10	5	YBHH16045	BOLT, 1/2-13 X 1-1/4 GR 5
11	26	YNFG12006	HEX NUT, FLANGE, NYLOCK, 3/8-16
12	8	YNNY12005	HEX NUT, NYLON LOCKNUT, 3/8
13	5	YNTL16005	HEX NUT, TOP LOCK, 1/2-13



## **FIGURE 6**

### **FRONT IDLER SHAFT ASSEMBLY**

<b><u>ITEM</u></b>	<b><u>QTY</u></b>	<b><u>PART #</u></b>	<b><u>DESCRIPTION</u></b>
1	1	12N67	IDLER SHAFT
2	2	12N65	SPKT, APRON, 6
3	1	80N58	APRON CHAIN
*	1	11S23	67H ATTACHMENT LINK LH
*	1	11S24	ATT. LINK RH 67H
*	1	11S25	CONNECTOR LINK 67H
*	1	80N62	ASSM, 67H SLAT W/ATT LINK
4	2	G89	STRAIGHT ZERK 1/4-28 X 90
5	2	YBHH16190	BOLT, 1/2"-13 X 9-1/2"
6	7	YBCR12010	CARR, BOLT, 3/8"-16 X 1" GR 5
7	1	YBCR12020	CARR, BOLT, 3/8"-16 X 1-1/4" GR 5
8	2	YWFL16005	WASHER, FLAT, 1/2 USS
9	2	YNNY16005	HEX NUT, NYLON LOCKNUT, 1/2"-13
10	4	YNNY12005	HEX NUT, NYLON LOCKNUT, 3/8
11	4	YNFG12006	HEX NUT, FLANGE, NYLOCK, 3/8-16, GR F, ZINC
12	2	12N66	IDLER SPACER
13	1	17G177	BRKT, SPRING, MOUNT
14	1	80N55	APRON CHAIN TIGHTENER, RH
15	1	80N56	APRON CHAIN TIGHTENER, LH

**\*MEANS NOT SHOWN**

# FIGURE 7 FLOOR ASSEMBLY

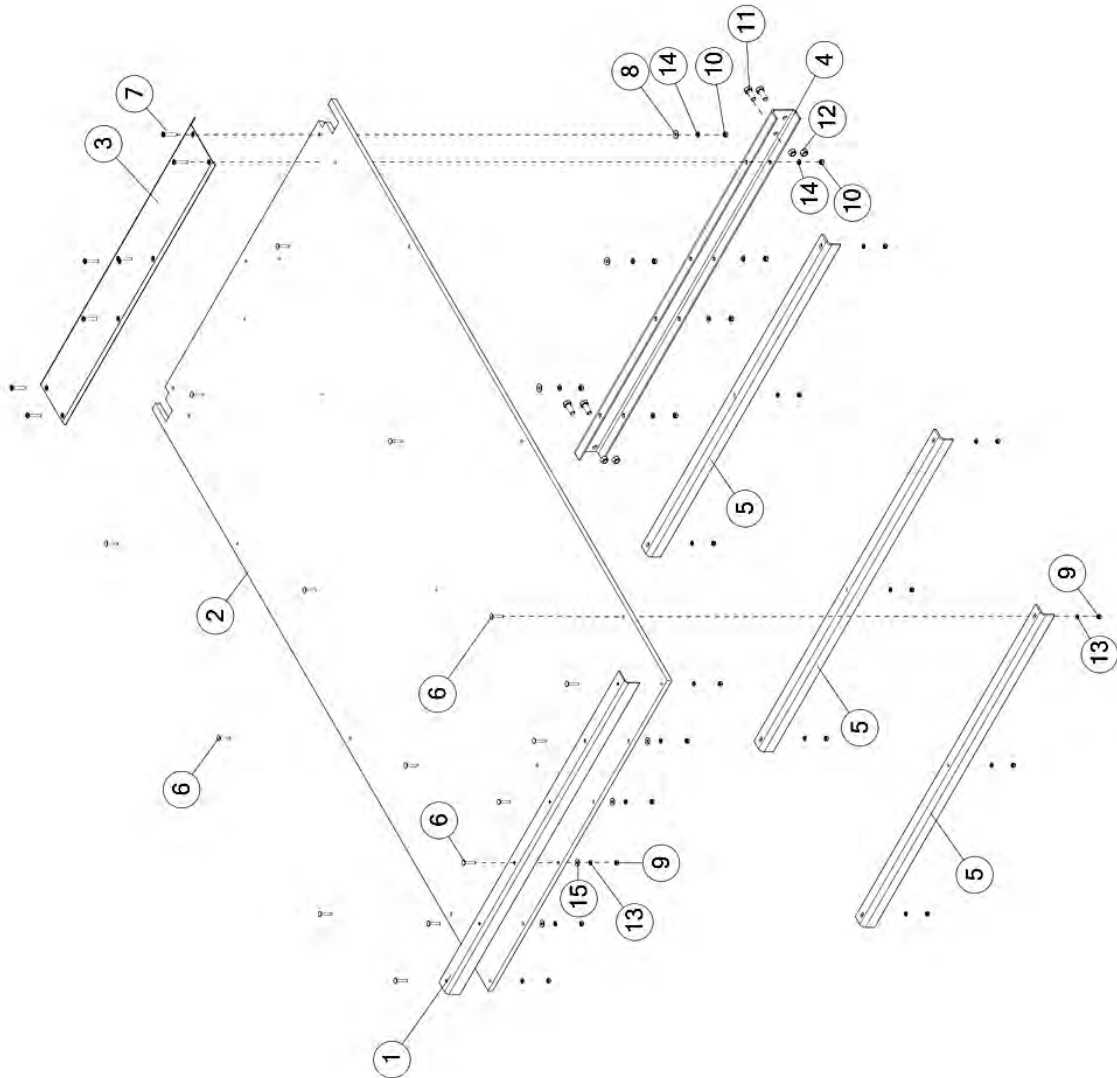



## **FIGURE 7** **FLOOR ASSEMBLY**

<b><u>ITEM</u></b>	<b><u>QTY</u></b>	<b><u>PART #</u></b>	<b><u>DESCRIPTION</u></b>
1	1	80N67	FRONT FLOOR BRACE
2	1	71430	POLY PLYWOOD, 80 PTO FLOOR, 5 PLY - 1/2" X 47-3/4" X 89-1/2"
3	1	71429	BACK REAR FLOOR BRACE
4	1	71433	BRKT, BACK CHANNEL
5	3	80G5	FLOOR BRACE
6	15	YBCR08010	CARR. BOLT, 1/4 X 1-1/2
7	7	YSFM10010	FLAT HEAD MACH, SCREW, 5/16 X 1-3/4
8	3	YWFL10005	WASHER, FLAT, 5/16 USS
9	15	YNHX08007	HEX NUT, 1/4-20 GR 5
10	7	YNHX10010	HEX NUT, 5/16-18 GR 5
11	4	YBHH16045	BOLT, 1/2-13 X 1-1/4 GR 5
12	4	YNL16005	HEX NUT, TOP LOCK, 1/2-13
13	15	YWLO08005	WASHER, LOCK, 1/4
14	4	YWLO10005	WASHER, LOCK, 5/16
15	4	YWFL08005	WASHER, FLAT, 1/4 USS



## FIGURE 8

### REAR IDLER SHAFT ASSEMBLY

<u>ITEM</u>	<u>QTY</u>	<u>PART #</u>	<u>DESCRIPTION</u>
1	1	67844	SHAFT, RND, 1.25, 52.1
2	1	80N58	ASSM, APRON CHAIN
3	3	G12	WOODRUFF KEY, 5/16" X 1.00"
4	1	71162	ASSM, SPKT, 50, B, 32, WITH DECALS
5	2	80N63	APRON DRIVE SPROCKET, 6T
6	1	L10R35	ASSY, TIGHTENER BRACKET
7	2	G89	ZERK, 1/4"-28 STRAIGHT
8	1	YBCR12010	CARR. BOLT, 3/8 X 1 GR. 5
9	1	YNFG12006	HEX NUT, FLANGE, NYLOCK, 3/8-16, GR F, ZINC
10	3	YSKP10005	SET SCREW, SOCKET, KNURLED CUP PT, 5/16"-18 X 1/2"
11	2	YSKP12035	SET SCREW, SCKT, KNRD CUP PT 3/8-16 X 3/4
12	1	70193	CHAIN, ROLL, 50 X 45
13	1	69786	SPKT, 50, B, 16, 1.50 SHAFT
14	1	23N238	CHAIN TIGHTENER ROLLER
15	1	10R32	SNAP RING

# FIGURE 9 SIDE SHAFT ASSEMBLY

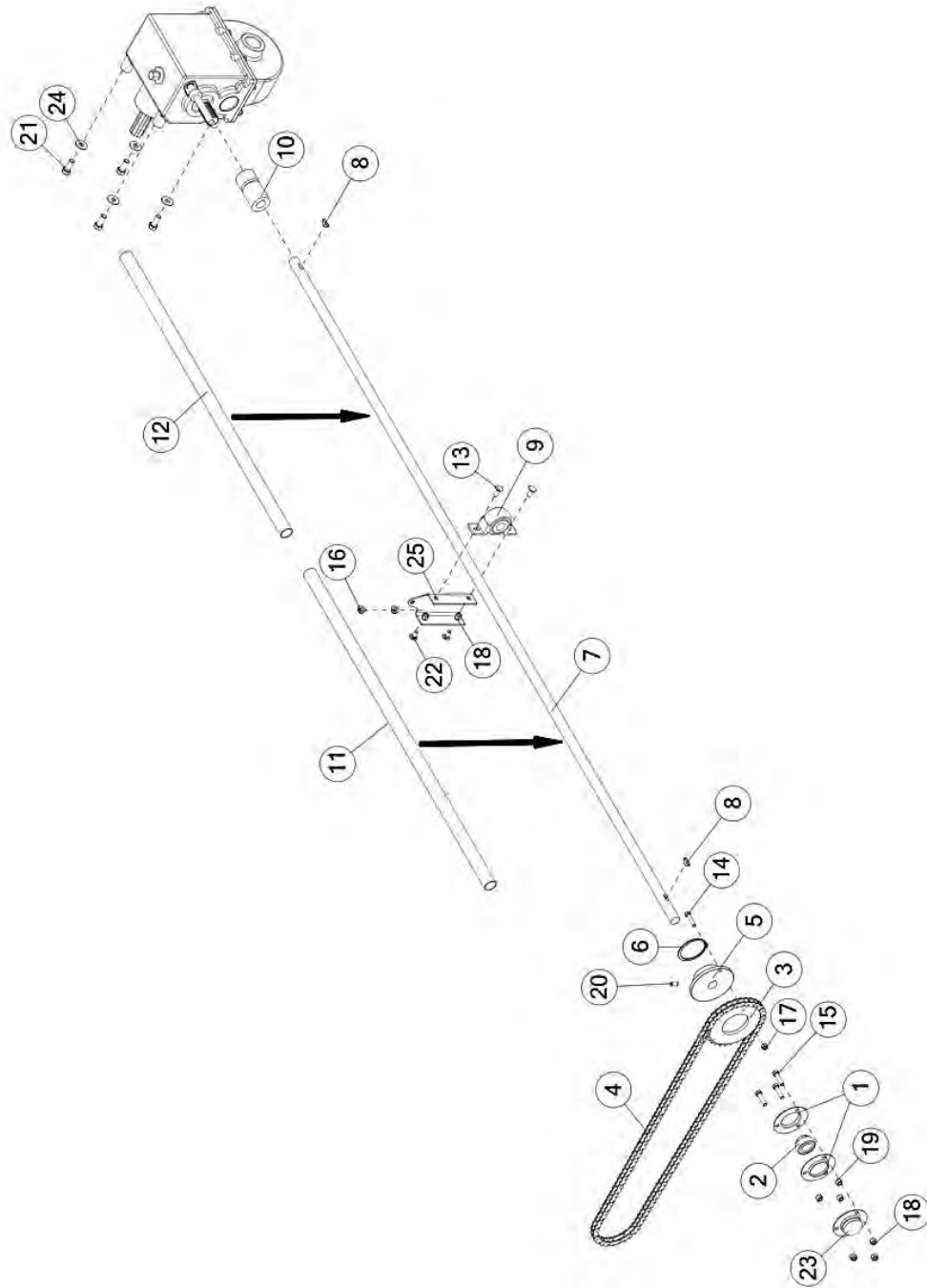

## FIGURE 9

### SIDE SHAFT ASSEMBLY

<u>ITEM</u>	<u>QTY</u>	<u>PART #</u>	<u>DESCRIPTION</u>
1	2	4C7	FLANGE, BEARING, Ø3.75 OD, Ø1.98 ID
2	1	4C8	BEARING W/COLLAR, 1.00"
3	1	69785	SPKT, 50, A, 30
4	1	70200	CHAIN, ROLL, 50 X 119
5	1	80N74	SHEAR HUB
6	1	23N75	STANDARD EXTERNAL SNAP RING, 2.93"
7	1	67793	SHAFT, RND, 1.0, 94.26
8	2	5B10	KEY, WOODRUFF, 1/4" X 1.00"
9	1	80N22	BEARING, 1.00"
10	1	69807	WLDMT, COUPLER, S2180
11	1	69010	TUBE, RND, STR, 1.64 X 0.14 X 44.7, PVC
12	1	69011	TUBE, RND, STR, 1.64 X 0.14 X 39.6, PVC
13	2	YBCR12010	CARR. BOLT, 3/8 X 1 GR. 5
14	1	YBHH10025	BOLT, 5/16 X 1-1/2 GR 2
15	3	YBHH12025	BOLT, 3/8-16 X 1-1/2 GR 5
16	2	YNFG12006	HEX NUT, FLANGE, NYLOCK, 3/8-16, GR F, ZINC
17	1	YNNY10005	HEX NUT, NYLON LOCKNUT, 5/16-18
18	5	YNNY12005	HEX NUT, NYLON LOCKNUT, 3/8
19	3	YNTL12005	HEX NUT, TOP LOCK, 3/8-16
20	1	YSKP12035	SETSCR, SCKT, KNRD CUP PT 3/8-16 X 3/4
21	4	YBHH16045	BOLT, 1/2-13 X 1-1/4 GR 5
22	2	YBCR12065	CARR. BOLT, 3/8 X 3/4 GR 5
23	1	80N15	ASSY, SHAFT GUARD
24	4	YWFL16005	WASHER, FLAT, 1/2 USS
25	1	70130	PLT, 5.72 X 5.31 X 0.13

# FIGURE 10

## SIDE SHAFT PANEL & GUARDS

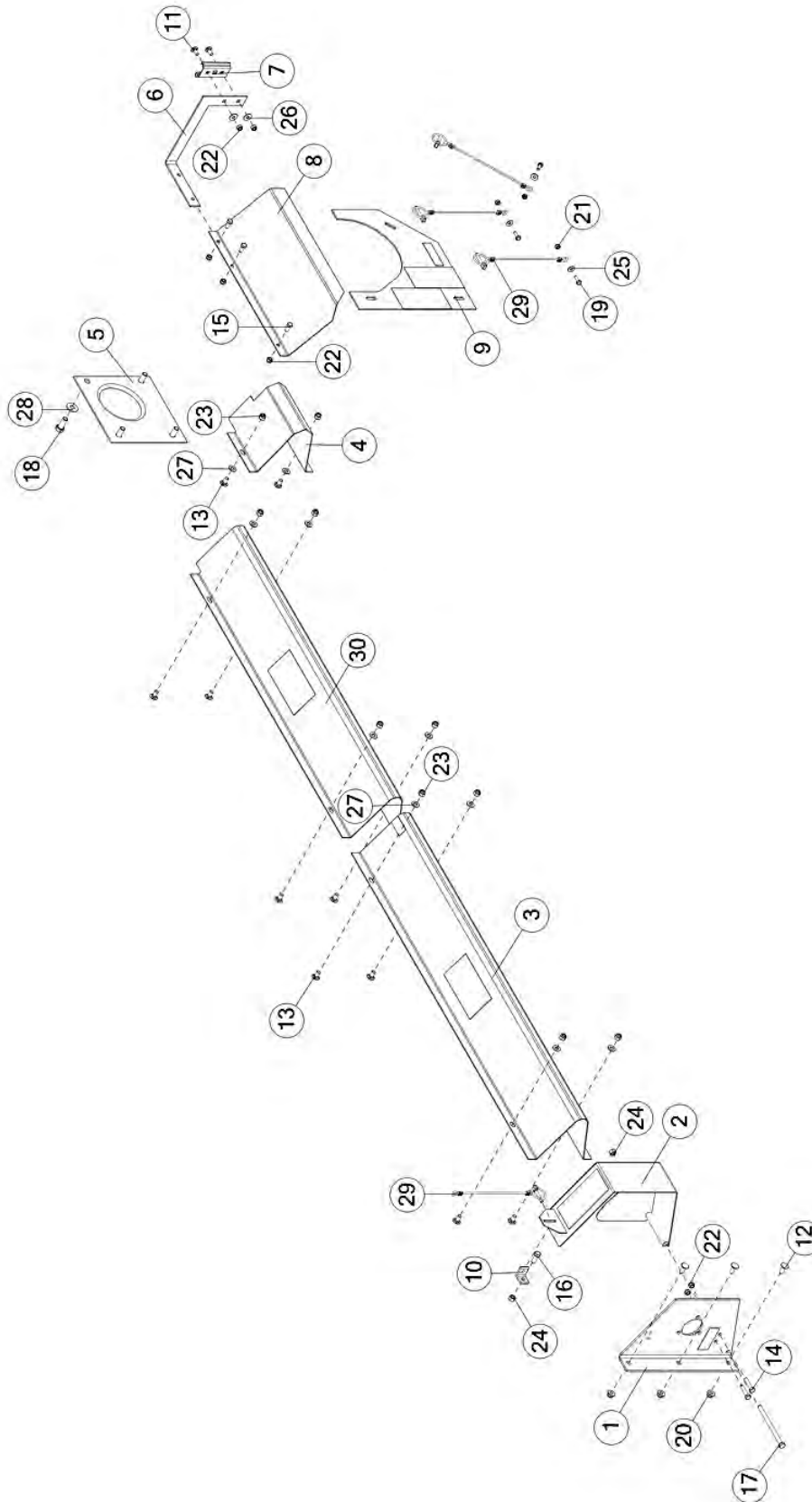

## FIGURE 10

### SIDE SHAFT PANEL & GUARDS

<u>ITEM</u>	<u>QTY</u>	<u>PART #</u>	<u>DESCRIPTION</u>
1	1	71000	ASSM, BRKT, SIDE SHAFT, WITH DECALS ASSM,
2	1	71156	SPKT, SHIELD WITH DECALS
3	1	72089	SHIELD ASSY, SIDE SHAFT FRONT, WITH DECALS
4	1	71431	SHLD, 7.50 X 7.91 X 0.08, COUPLER
5	1	69964	PLT, 9.50 X 9.50 X 0.14
6	1	70192	BRKT, SMV
7	1	F97	SMV BRACKET
8	1	71160	ASSM, GRBX SHIELD WITH DECALS
9	1	72077	SHIELD ASSY, POLY WITH DECALS
10	1	F92	FRONT SHIELD BRACKET
11	2	YBCR10030	CARR. BOLT, 5/16 X 3/4 GR 5
12	3	YBCR12010	CARR. BOLT, 3/8 X 1 GR. 5
13	10	YBCR12065	CARR. BOLT, 3/8 X 3/4 GR 5
14	2	YBHH10025	BOLT, 5/16 X 1-1/2 GR 2
15	3	YBHH10105	BOLT, 5/16 X 3/4 GR 5
16	1	YBHH12010	BOLT, 3/8 X 1 GR 5
17	1	YBHH12210	BOLT, 3/8-16 X 5-1/2 GR 2 ZINC
18	4	YBHH16045	BOLT, 1/2-13 X 1-1/4 GR 5
19	3	YBHH08100	BOLT, 1/4 X 3/4 GR 5
20	3	YNFG12006	HEX NUT, FLANGE, NYLOCK, 3/8-16, GR F, ZINC
21	3	YNNY08005	HEX NUT, NYLON LOCKNUT, 1/4-20
22	4	YNNY10005	HEX NUT, NYLON LOCKNUT, 5/16-18
23	10	YNNY12005	HEX NUT, NYLON LOCKNUT, 3/8
24	2	YNTL12005	HEX NUT, TOP LOCK, 3/8-16
25	3	YWFL08005	WASHER, FLAT, 1/4 USS
26	2	YWFL10005	WASHER, FLAT, 5/16 USS
27	10	YWFL12010	WASHER, FLAT, 3/8 SAE, GR 8, YELLOW ZINC
28	4	YWFL16005	WASHER, FLAT, 1/2 USS
29	4	S122	LANYARD, CLIP PIN CABLE
30	1	72090	SHIELD ASSY, SIDE SHAFT FRONT, WITH DECALS

**FIGURE 11**  
**HUB & SPINDLE ASSEMBLY**

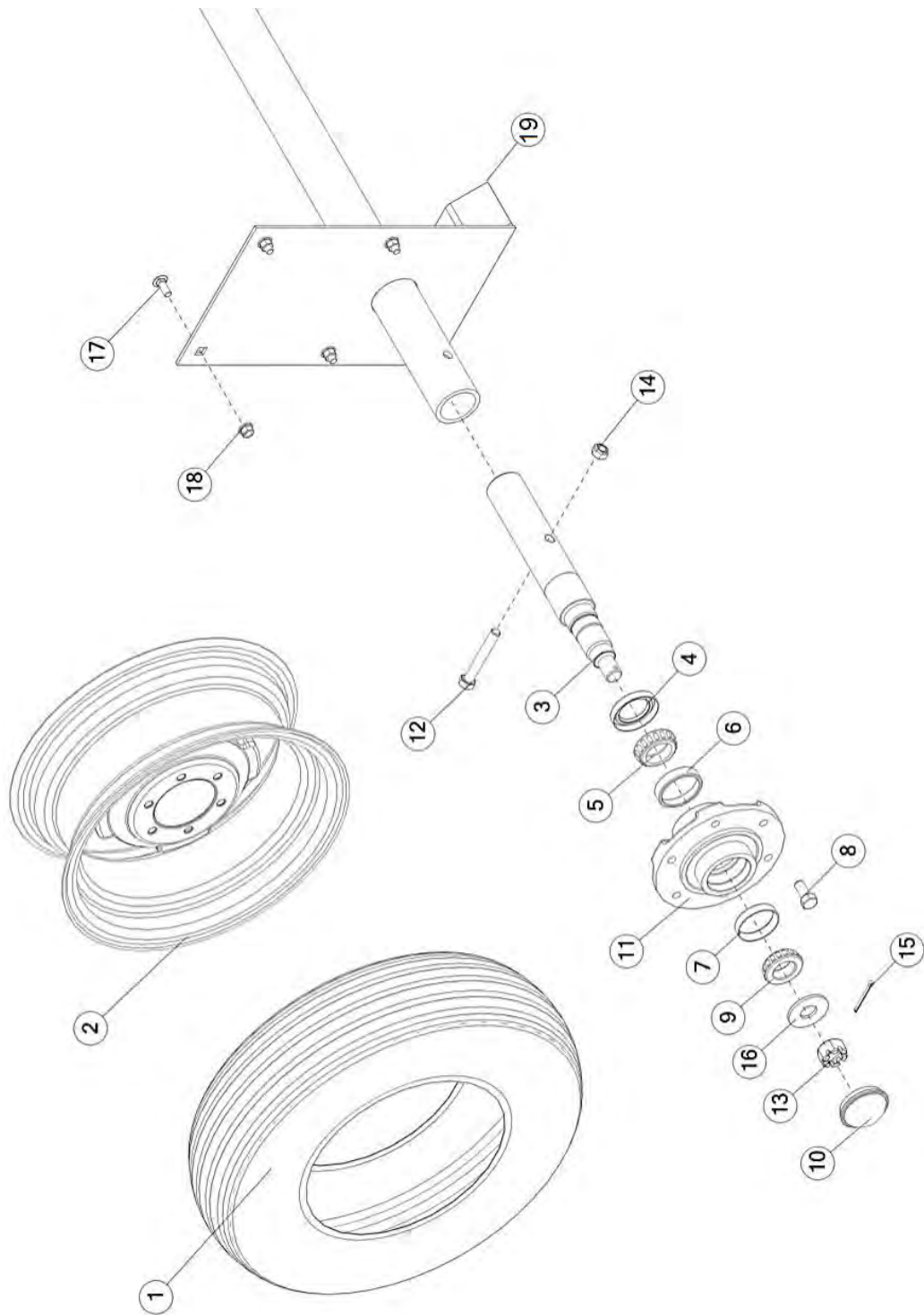



# FIGURE 11

## HUB & SPINDLE ASSEMBLY

<u>ITEM</u>	<u>QTY</u>	<u>PART #</u>	<u>DESCRIPTION</u>
1	2	80N93	TIRE, 6.70 X 15SL
2	2	71174	WHEEL, 15 X 5, 6 BOLT, 1.125
3	2	12N16	2.00" X 14.000" SPINDLE
4	2	12N17	SEAL
5	2	12N18	INNER BEARING
6	2	12N19	INNER RACE
7	2	17G146	OUTER RACE
8	12	12N22	WHEEL BOLT, 1/2-20 X 1.00", GR. 5, ZINC
9	2	17G145	OUTER BEARING
10	2	17G144	HUB CAP
11	2	12N20	ASSM, W/RACES
12	2	YBHH16115	BOLT, 1/2 X 3-1/2 GR 5
13	2	YNSL28005	HEX NUT, SLOTTED, 7/8-14
14	2	YNTL16005	HEX NUT, TOP LOCK, 1/2-13
15	2	YPCT05010	COTTER PIN 5/32" X 1-1/2"
16	2	YWFL28005	WASHER, FLAT, 7/8 USS, ZINC
17	8	YBCR12010	CARR. BOLT, 3/8 X 1 GR. 5
18	8	YNFG12006	HEX NUT, FLANGE, NYLOCK, 3/8-16, GR F, ZINC
19	1	80N54	AXLE WELD-UP

# FIGURE 12 BEATER ASSEMBLY

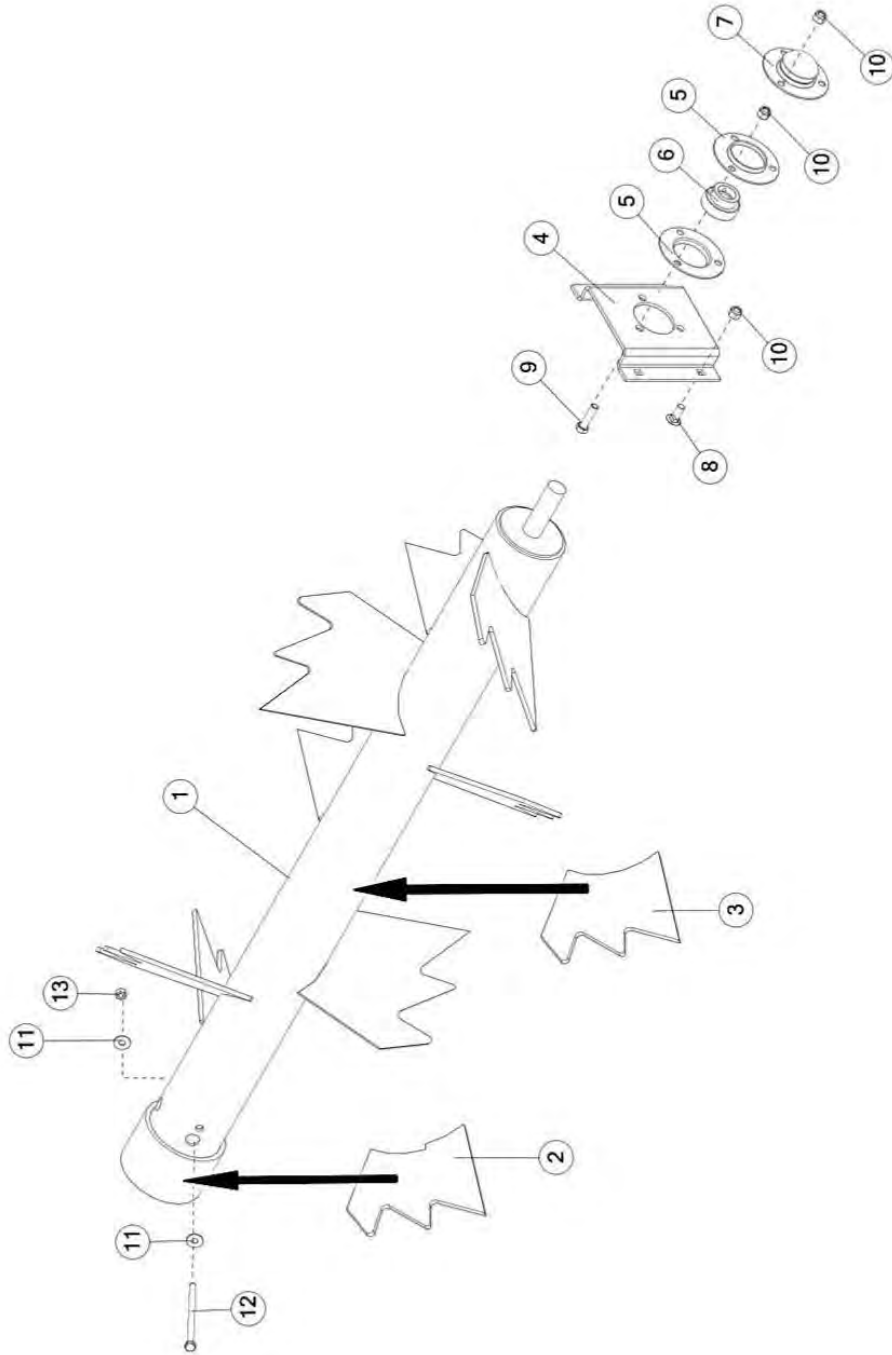

## FIGURE 12

### BEATER ASSEMBLY

<u>ITEM</u>	<u>QTY</u>	<u>PART #</u>	<u>DESCRIPTION</u>
1	1	71392	WLDMT, BEATER
2	1	71396	BEATER BLADE, SPLINE END
3	9	71391	BEATER BLADE
4	1	80N52	BEATER BEARING MOUNT
5	2	4C7	FLANGE, BEARING, Ø3.75 OD, Ø1.98 ID
6	1	4C8	BEARING W/COLLAR, 1.00" ASSY,
7	1	80N15	SHAFT GUARD
8	4	YBCR12010	CARR. BOLT, 3/8 X 1 GR. 5
9	3	YBHH12025	BOLT, 3/8-16 X 1-1/2 GR 5
10	10	YNNY12005	HEX NUT, NYLON LOCKNUT, 3/8
11	1	YNL10005	WASHER, FLAT, 5/16 USS
12	1	YBHH10130	BOLT, 5/16 X 5 GR 5
13	1	YNL10005	HEX NUT, TOP LOCK, 5/16-18

**FIGURE 13**  
**GEARBOX**

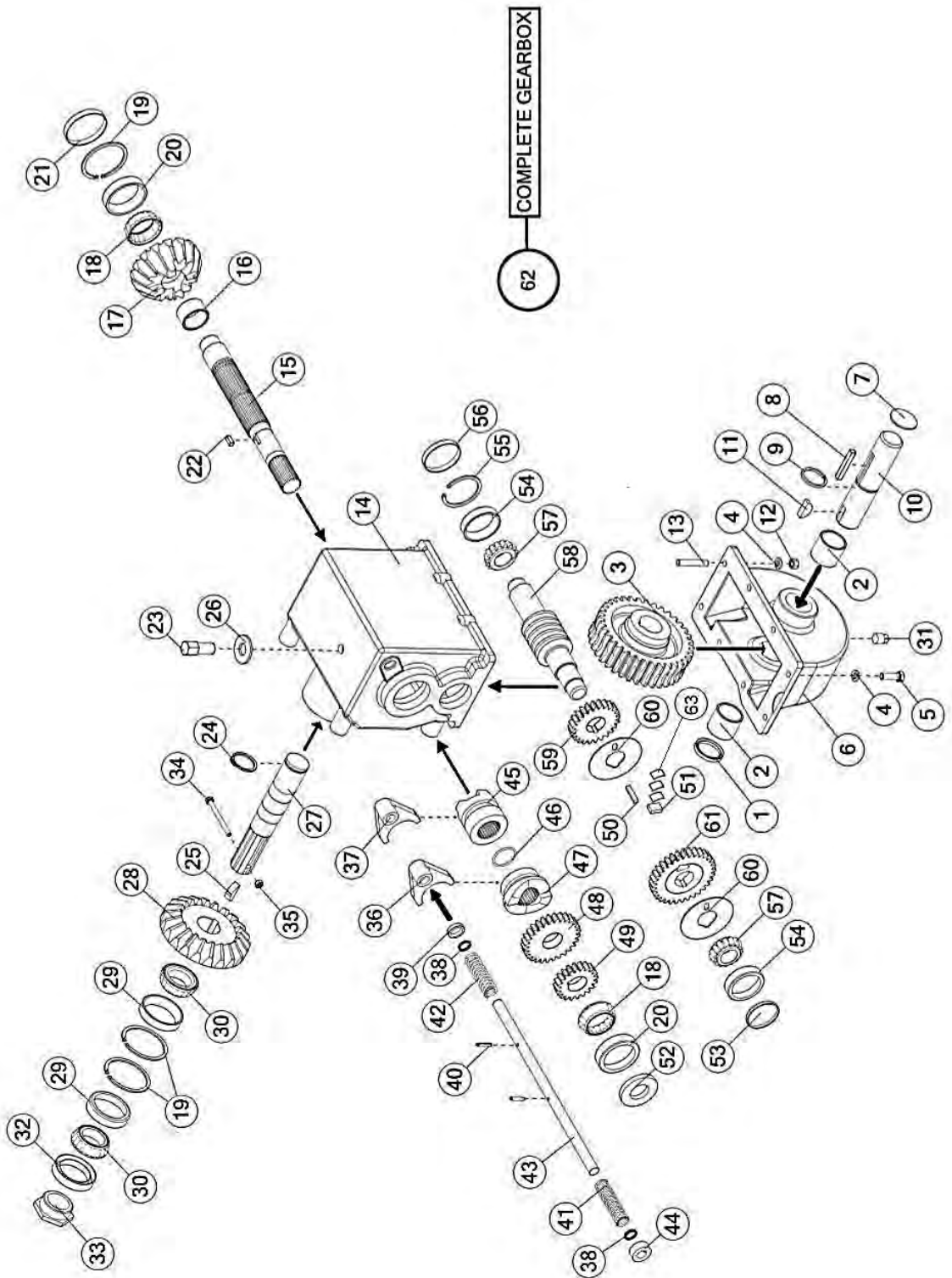

## FIGURE 13 GEARBOX

<u>ITEM</u>	<u>QTY</u>	<u>PART #</u>	<u>DESCRIPTION</u>
1	1	17G133	SEAL, 1.88 X 1.50 X 0.25
2	2	17G134	BSH, 1.75 X 1.50 X 1.50, BRZ
3	1	17G137	GEAR, WORM, 36T, 6 PITCH, 2 SPEED GEAR BOX
4	8	YWLO12005	WASHER, LOCK, 3/8
5	6	YBHH12040	BOLT, 3/8 X 1-1/4 GR 5 FULL THREAD
6	1	17G107	CAST, HSG, GRBX, LOWER
7	1	17G139	CAP, 1.75
8	1	17G132	KEY, SQ, 0.31 X 0.31 X 2.25
9	1	17G135	SNAP RING, 1.424 ID X .125 WT
10	1	17G136	SHAFT, RND, 1.50, 7.093, WORM GEAR OUTPUT
11	1	5B9	KEY, WDF, 0.38 X 0.53 X 1.25
12	2	YNHX12005	HEX NUT, 3/8-16 GR 2
13	2	17G138	SCR, STUD, 0.38-16 X 2.0
14	1	17G99	CAST, HSG, GRBX, UPPER
15	1	17G108A	SHAFT, RND, 1.75, 12.82, PTO INPUT
16	1	17G111	BSH, 1.75 X 1.5 X 1.0, BRZ
17	1	17G110	GEAR, BEVEL, 16T, WITH 4 JAW
18	2	G18	BRG, 2.24 X 1.58 X .82, TAPER
19	3	G55	RING, SNAP, INTERNAL, 3.02 X 2.64
20	2	G54	BEARING, ROLL, CUP, 2.72,
21	1	G68	CAP, 2.72
22	1	17G116	KEY, SQ, 0.25 X 0.25 X 0.63
23	1	17G58	VENT CAP
24	1	12V62	HEAVY DUTY EXTERNAL SNAP RING, 1.50" KEY,
25	1	G61	WDF, 0.38 X 0.55 X 1.25
26	1	17G61	WASH, FLAT, 1.77 X 0.77 X 0.13
27	1	17G104	SHAFT, RND, 1.50, 9.0, BEATER OUTPUT GEAR,
28	1	17G101	BEVEL, 22T
29	2	17G102	BEARING, ROLL, CUP, 2.72,
30	2	17G103	BRG, 2.35 X 1.50 X 0.75, TAPER
31	1	G65	PLUG, PIPE 3/8-18 NPT

**FIGURE 13**  
**GEARBOX**

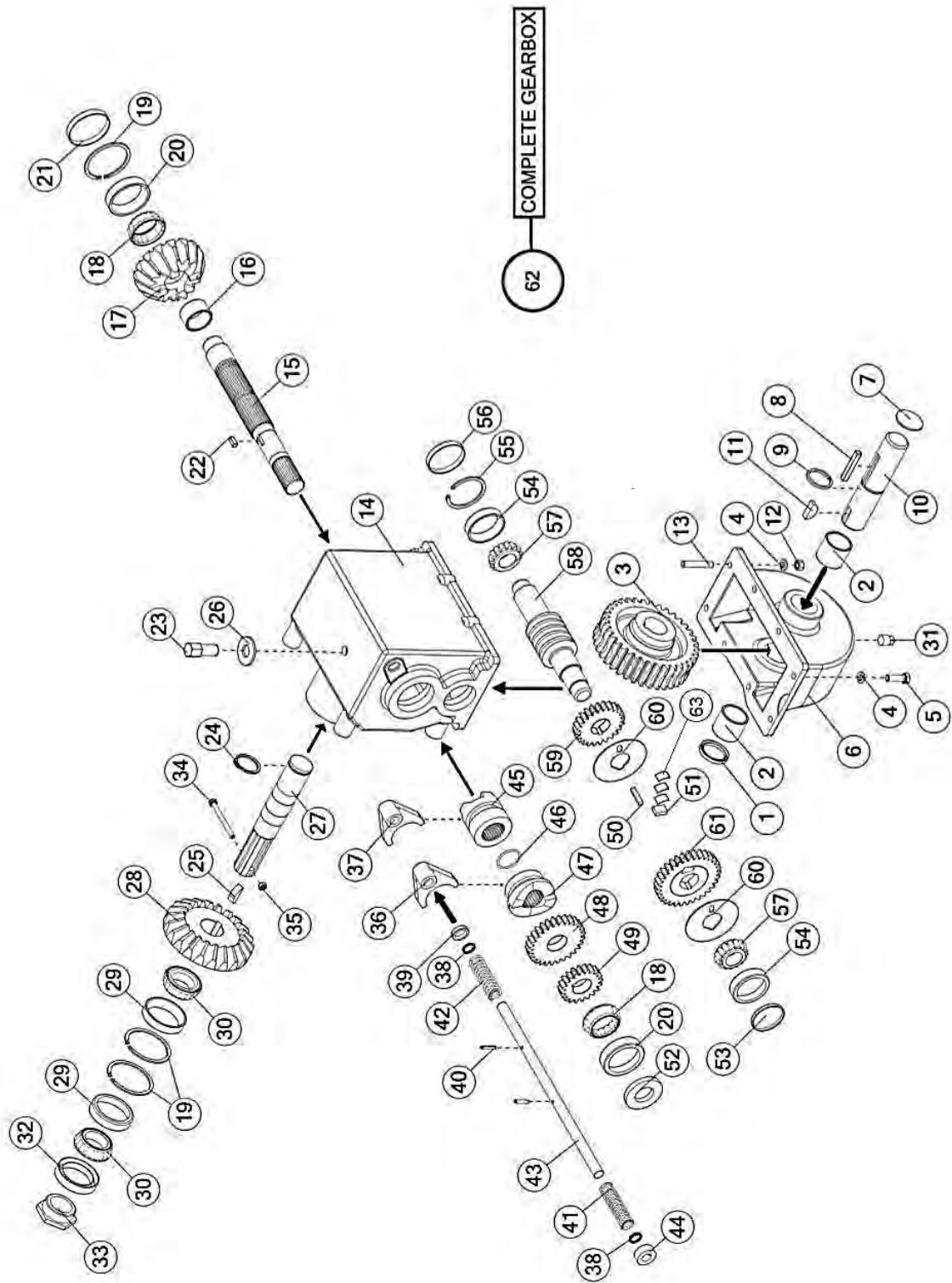

## **FIGURE 13**

### **GEARBOX**

<b><u>ITEM</u></b>	<b><u>QTY</u></b>	<b><u>PART #</u></b>	<b><u>DESCRIPTION</u></b>
32	1	17G105	SEAL, 2.72 BORE, 2.00 SHAFT
33	1	17G106	NUT, HEX, 1.50-18, NA
34	1	YBHH08080	BOLT, 1/4 X 3 GR 2 FULL THREAD
35	1	YNHX08007	HEX NUT, 1/4-20 GR 5
36	1	17G125	YOKE, SHIFTER, HIGH SPEED
37	1	17G129	YOKE, SHIFTER, BEATER
38	2	17G121	SEAL, .813 BORE X .625 SHAFT
39	1	17G122	TUBE, RND, STR, 1.06 X 0.14 X 0.25
40	2	17G123	PIN, ROLL, 0.19 X 1.0, ZN
41	1	17G128	SPRG, COIL, 3.36, COMP
42	1	17G130	SPRG, COIL, 3.13, COMP
43	1	17G131	SHAFT, RND, 0.625, 15.0, SHIFTER ROD
44	1	17G171	COLLAR, LOCK, 1.25X.629,
45	1	17G109	BEATER CLUTCH, 2 SPEED GEAR BOX
46	1	17G169A	RING, SNAP, 1.57 X 1.38
47	1	17G119	HIGH SPEED CLUTCH, 2 JAW
48	1	17G118	GEAR, 28T, HIGH SPEED W/2 JAWS
49	1	17G115	GEAR, LOW SPEED, 2 SPEED GEAR BOX
50	1	S135	KEY, SQ, 0.25X0.25X1.25
51	1	17G124	KEY, 0.75 X 0.25 X 0.56
52	1	S136	SEAL, OIL, 1.25 ID X 2.44 OD X .31 THK
53	1	17G100	CAP, 2.14
54	2	3G18	BEARING, ROLL, CUP, 2.54,
55	1	3G19	RING, SNAP, INTERNAL, 2.59 X 2.22
56	1	G90	CAP
57	2	L3G24	BRG, 1.75 X 1.13 X 0.81, TAPER
58	1	17G120	SHAFT, RND, 2.33, 9.84
59	1	17G117	GEAR, HIGH SPEED, 2 SPEED GEARBOX
60	2	17G112	WASH, FLAT, 3.50, 1.26
61	1	17G114	CLUTCH, LOW SPEED, 2 SPEED
62	1	17G142	GEARBOX ASSM, 2 SPEED GEARBOX
63	3	17G126	SPRG, DOG, 0.552 X 0.75

**FIGURE 14**  
**PTO**

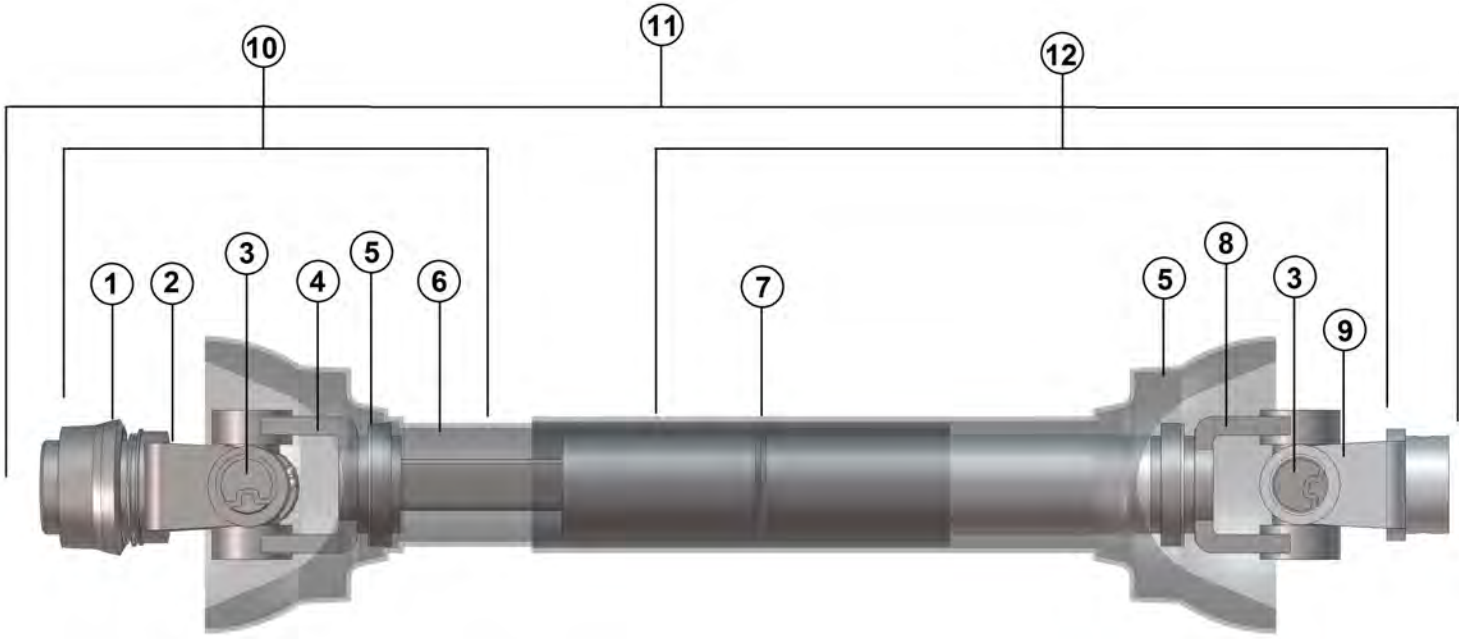



## **FIGURE 14**

### **PTO**

<b><u>ITEM</u></b>	<b><u>QTY</u></b>	<b><u>PART #</u></b>	<b><u>DESCRIPTION</u></b>
1	1	S225	SPRING-LOK REPAIR KIT
2	1	S379	SPRING-LOK YOKE ASSEMBLY
3	2	T274	12P CROSS AND BEARING KIT
4	1	80N88	YOKE AND SHAFT
5	2	S206	GUARD REPAIR KIT (NOT SHOWN)
6	1	80N90	INNER GUARD
7	1	80N89	OUTER GUARD
8	1	80N91	YOKE AND TUBE
9	1	80N92	YOKE
10	1	80N84	JOINT & SHAFT HALF ASSEMBLY W/ GUARD
11	1	80N83	COMPLETE PTO ASSEMBLY
12	1	80N86	JOINT & TUBE HALF ASSEMBLY W/ GUARD
*	1	S402	PTO SAFETY MANUAL

**\*MEANS NOT SHOWN**

# FIGURE 15 OPTIONAL PAN

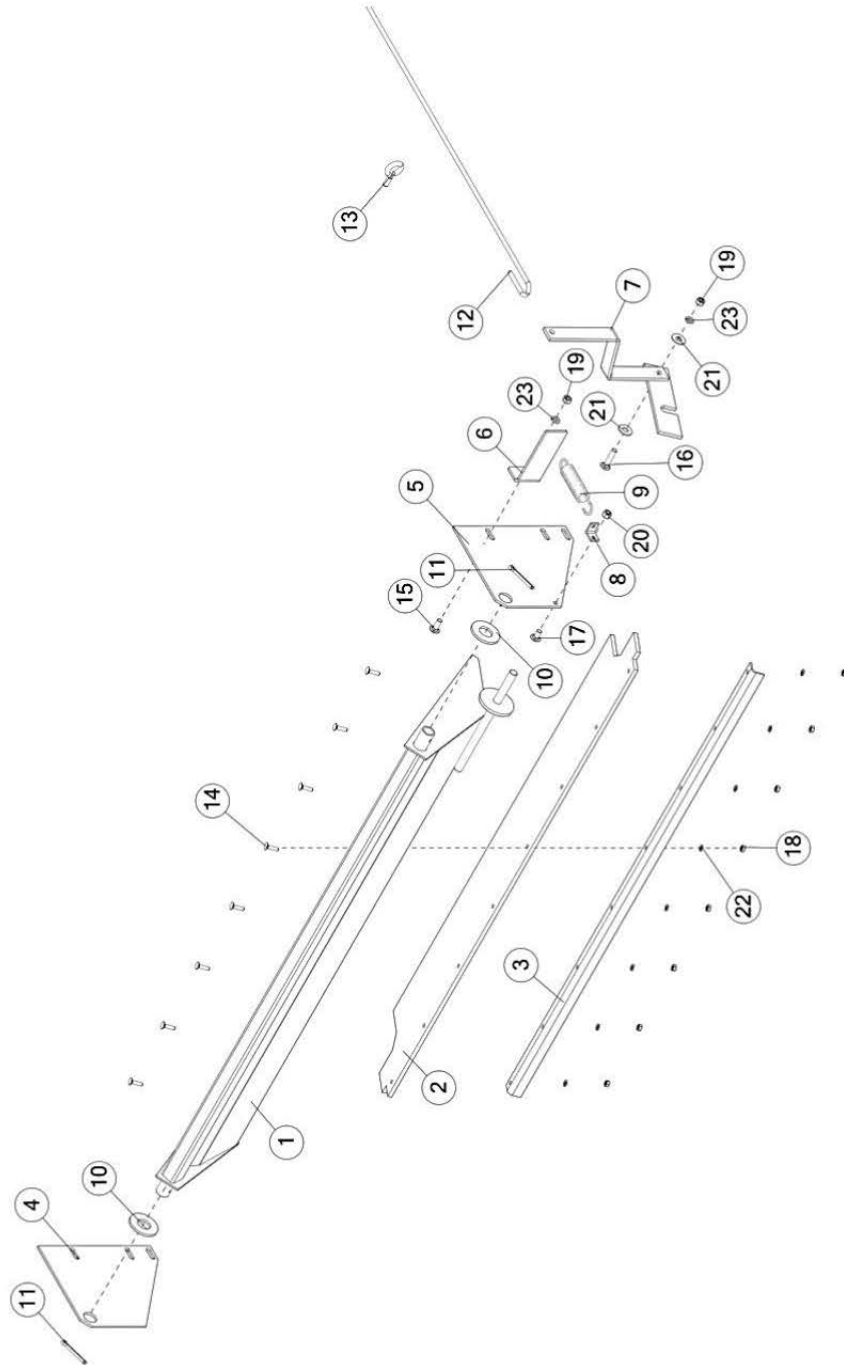

## FIGURE 15 OPTIONAL PAN

<u>ITEM</u>	<u>QTY</u>	<u>PART #</u>	<u>DESCRIPTION</u>
1	1	80N1	PAN
2	1	12N53	PAN RUBBER
3	1	12N52	RUBBER FLAP ANGLE
4	1	80N2	PAN PLATE, LH
5	1	80N3	PAN PLATE, RH
6	1	80N82	PAN HANDLE STOP
7	1	5N67	PAN HANDLE
8	1	R26	SPRING ANGLE
9	1	R27	SPRING
10	2	R3	PAN SPACER
11	2	YPCT08007	COTTER PIN, 1/4 X 2
12	1	80N6	TRIP ROPE
13	1	YBTE12005	TURNTD EYE BOLT, 3/8-16 X 1" SHANK, 2-1/2" OAL
14	8	YBCR08005	CARR. BOLT, 1/4-20 X 1 GR. 5 (ZINC)
15	1	YBCR12010	CARR. BOLT, 3/8 X 1 GR. 5
16	1	YBCR12030	CARR. BOLT, 3/8 X 1-3/4 GR 5
17	1	YBCR12065	CARR. BOLT, 3/8 X 3/4 GR 5
18	8	YNHX08005	HEX NUT, 1/4
19	2	YNHX12005	HEX NUT, 3/8-16 GR 2
20	1	YNTL12005	HEX NUT, TOP LOCK, 3/8-16
21	1	YWFL14005	WASHER, FLAT, 7/16 USS
22	8	YWLO08005	WASHER, LOCK, 1/4
23	2	YWLO12005	WASHER, LOCK, 3/8





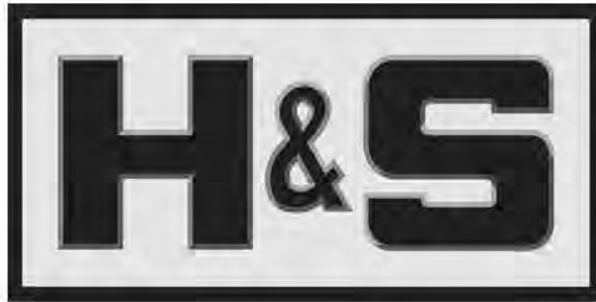

**H&S Manufacturing products are approved for the  
FEMA SEAL OF QUALITY**

**P.O. BOX 768, MARSHFIELD, WI 54449  
(715) 387-3414 FAX (715) 384-5463  
[www.hsmfgco.com](http://www.hsmfgco.com)**